

SECTION A INLINE DIKE JOINT

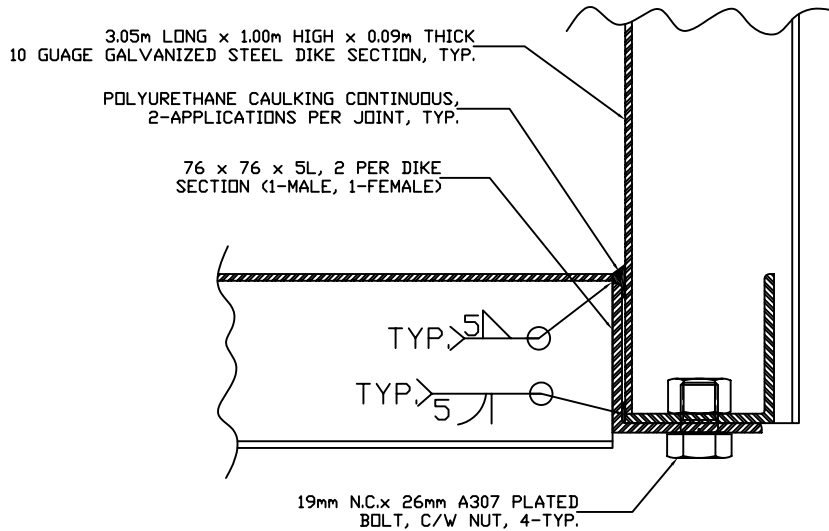

SECTION B CORNER DIKE JOINT

NOTES:

- ALL STEEL CONFORMS TO CSA G40.21-M
- ALL GALVANIZED COMPONENTS CONFORM TO CSA G164-M
- DIKE SYSTEM UTILIZES THE PATENTED MILEPOST JOINT DESIGN.
- KNEEBRACE NOT SHOWN FOR CLARITY

		MILEPOST MFG. a div. of MILEPOST OILFIELD SERVICES LTD.		SHOP DRAWING	
Designed by S.D.	Checked by P.C.	Approved by - date -	File name STEELDIKEKBJO	Date 06/04/06	Scale NTS
STEEL CONTAINMENT DIKE SECTION JOINT DETAIL					
			Edition 0	Sheet 1/1	